

# S.50-610

Ideal for dairy, vegetables, poultry, snacks, sweets and other industries that handle products requiring drainage and small openings. FDA approved

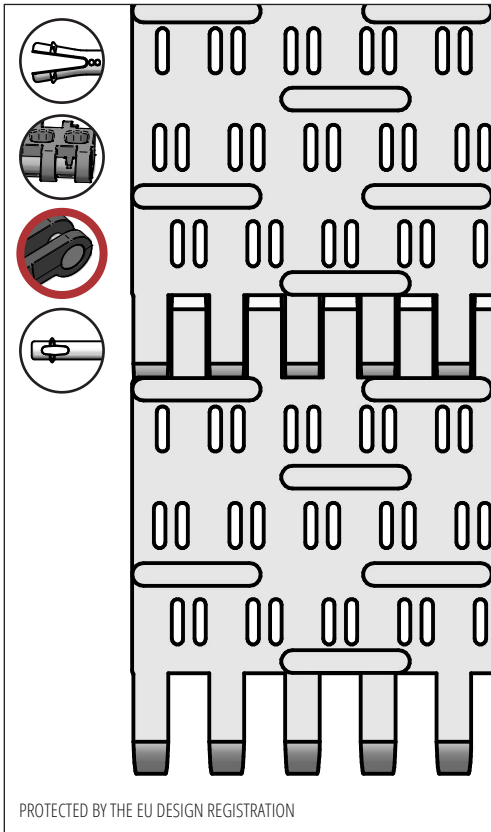

**SCANBELT**  
...keeping industry moving...



PROTECTED BY THE EU DESIGN REGISTRATION

## SUGGESTED INDUSTRIES



## STANDARD FEATURES

Belt surface	Perforated flat top with 1 mm ribs
Open area	9 %. Open area. Biggest opening 1,5 x 6 mm
Strength	The right belt for medium-heavy transportation
Cleanability	Excellent. FSIS
Standard width	Increments of 10 mm, e.g. 100, 110 mm etc.

## BELT DATA

Belt materials	Temperature range		Max. belt pull kg/m of width	Belt weight kg/m <sup>2</sup>	Belt weight kg/m <sup>2</sup> w. steel rods	Standard Colours
	Min.	Max.				
PE	- 73	66	1790	7	11	Blue/Natural
PP	+ 5	100	2400	7	11	Blue/White/Grey
POM	- 43	95	3600	11	15	Blue/Natural

## ACCESSORIES

Type	mm
Flights	25*, 50*, 75*, 100*
Scoop Flights	50, 75, 100, 150
Bent Flights	75*, 100*
Supported Flights	75, 100, 150
Flights fitted with a Round Top	Yes
Side Guard	50, 75, 100, 150
Friction Top	Yes
Hold-downs	Yes

\*Modules can be supplied with a moulded indent of 40 mm.

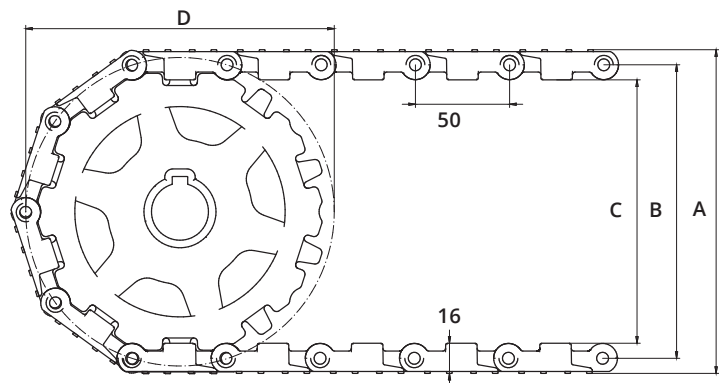

## SPROCKET DATA

A = Outside, B = Pitch, C = Inside, D = Pitch Circle Diameter

No. Teeth	A mm	B mm	C mm	D mm	Hub Width mm	Round Bore		Square Bore	
						mm	Inch	mm	Inch
6	104	88	72	101	20	25 / 30 / 40	¾ / 1 / 1¼	25 / 40	1½
8	138	122	106	133	35	25 / 30 / 40	1 / 1¼	25 / 40	1½
10	172	156	140	164	35	25 / 30 / 40	1 / 1¼	20 / 25 / 40 / 60 / 50 / 60 / 80	1½ / 2½
12	205	189	173	195	35	25 / 30 / 40 / 50 / 60	1 / 1¼	25 / 40 / 60 / 80	1½ / 2½
16	270	254	238	258	35	60 / 80		40 / 60 / 80	