

S.50-918

Ideal choice for very heavy transportation.
Assembling belt for cars and truck loading systems.
FDA approved

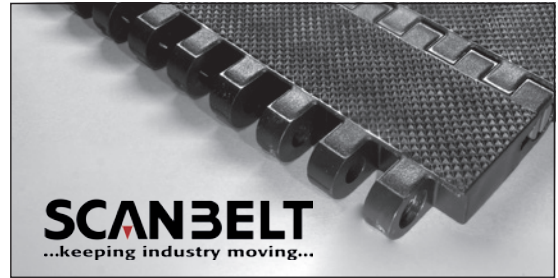

SCANBELT
...keeping industry moving...

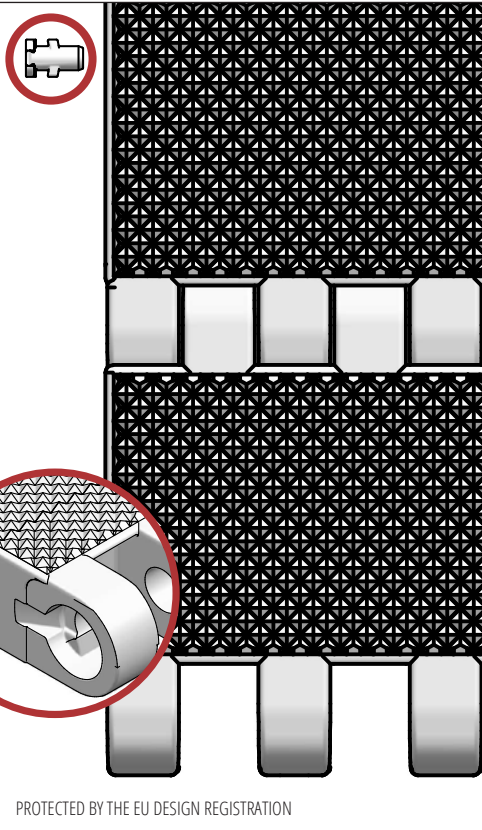

SUGGESTED INDUSTRIES



STANDARD FEATURES

Belt surface	Closed with 1 mm rough top
Open area	Closed
Strength	The right belt for very heavy applications
Cleanability	Good
Standard width	Increments of 20 mm, e.g. 100, 120 mm etc.

BELT DATA

Belt materials	Temperature range		Max. belt pull kg/m of width	Belt weight kg/m ²	Belt weight kg/m ² w. steel rods	Standard Colours
	Min.	Max.				
PE	- 73	66	4800	14	20	Black
PP	+ 5	100	6000	14	20	Black
POM	- 43	95	10250	21	27	Black

ACCESSORIES

Type	mm
Flights	25
Scoop Flights	-
Bent Flights	-
Supported Flights	-
Comb Flights	50, 60
Flights fitted with a Round Top	-
Side Guard	-
Friction Top	-
Hold-downs	-

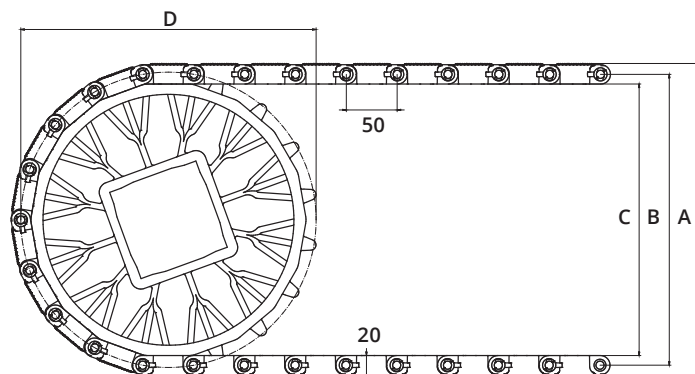

SPROCKET DATA

A = Outside, B = Pitch, C = Inside, D = Pitch Circle Diameter

No. Teeth	A	B	C	D	Hub Width	Round Bore		Square Bore	
	mm	mm	mm	mm		mm	Inch	mm	Inch
12	209	188	169	195	40	40 / 60		60 / 80 / 90	
16	275	254	235	259	40	40 / 60		60 / 80 / 90	
18	309	288	269	291	40	40 / 60		60 / 80 / 90	